

DRINKS | Minibar

MINIBAR TERMoeLETRICI

MB 52



DETTAGLI



Serratura di serie



Scheda termostato con manopola per regolazione temperatura



Maniglia integrata nel profilo della porta



Ripiani interni alla porta



CARATTERISTICHE GENERALI

Refrigeratore termoelettrico 48 Lt.	•
Refrigerazione statica con ventola interna di assistenza	•
Operatività silenziosa	•
Basse vibrazioni	•
Ridotta manutenzione necessaria	•
Schiumatura in Ciclopentano (40mm di spessore per lato - Senza CFC)	•
Termostato meccanico	•
Luce interna LED	•
Serratura di serie	•
Ripiani interni alla porta	•
Guarnizione Estraibile	•
Ripiani regolabili: 1 Pcs	•
Maniglia integrata nel profilo della porta	•
N.4 Piedini regolabili	•

SPECIFICHE TECNICHE

Dimensioni Esterne (LxPxH mm)	430x494x515
Dimensioni Interne (LxPxH mm)	356x336x410
Rumorosità	39 dB(A)
Consumo	0.51 kWh/24h
Capacità	48.5 L
Potenza Nominale	60 W
Peso Netto	10 Kg
Temperatura	+6° ~ +12°C
Peso Lordo	12 Kg
Dimensioni Imballo (LxPxH mm)	460x515x530
Quantità di carico 20'/40'/40'HQ	220/460/572

CERTIFICAZIONI

CE  RoHS

INGOMBRO PRODOTTO

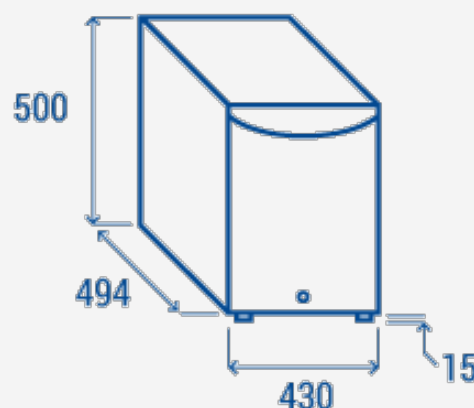

COOL HEAD EUROPE

We make the world a cooler place



www.coolheadeurope.com