

# DISPLAY | Espositori da banco

ESPOSITORI REFRIGERATI DA BANCO

## RG 1200



BAKERY

GAS  
R290

M1  
-1°C  
+5°C

C  
ENERGY  
CLASS

3  
+25°C/60RH



### DETTAGLI



Termostato Digitale



Ripiani regolabili in vetro



Luce LED interna



### Caratteristiche generali

- Espositore orizzontale refrigerato da banco
- Vetro quadrato con cornice nero e basamento in acciaio inox
- Refrigerazione Ventilata
- Evaporatore con copertura anti-corrosione
- Sbrinamento automatico a fermata compressore
- Controllo con display digitale
- Luce interna LED
- Doppio vetro temperato di sicurezza con Low-e (Vetri a bassa emissività)
- Porte scorrevoli posteriori
- Guide per scorrimento porte anteriori riscaldate
- Ripiani regolabili in vetro (N.2 Pcs)
- N.4 Piedini regolabili
- Classe energetica: C

### Specifiche tecniche

Capacità	280 L
Temperatura	M1 (-1°C-+5°C)
Consumo	8.1 kWh/24h
Potenza Nominale	500 W
Rumorosità	50 dB(A)
Peso Netto	120.00 Kg
Peso Lordo	148.00 Kg
Dimensioni Esterne (LxPxH mm)	1192x676x731
Dimensioni Interne (LxPxH mm)	1150x613x409
Dimensioni Imballo (LxPxH mm)	1260x750x850
Quantità di carico 20'/40'/40'HQ	26/54/81

### CERTIFICAZIONI

CE RoHS

### INGOMBRO PRODOTTO

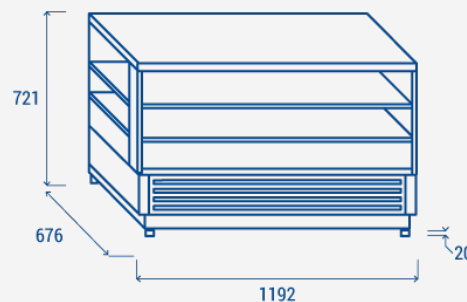

COOL HEAD EUROPE

We make the world a cooler place



www.coolheadeurope.com